

**HOUSTON LIVESTOCK SHOW AND RODEO™**

**ALL-BREED  
YOUTH HORSE SHOW  
PATTERN BOOK**

**March 14-15, 2019**

# Houston Livestock Youth Show

## Showmanship (Walk/Trot Showmanship)

Show Date: 03-14-2019

www.horsheshowpatterns.com

www.horsheshowpatterns.com

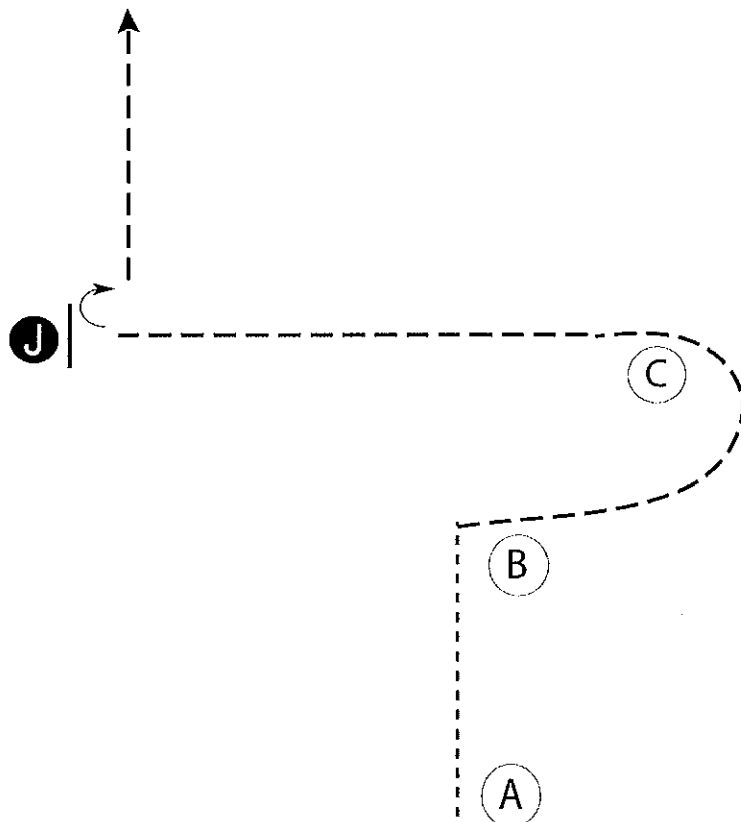

Be ready at A.

1. Walk to B.
2. Trot from B and around C as shown.
3. Continue to trot to judge and set up for inspection.
4. When dismissed, do a 90 degree turn and trot away.

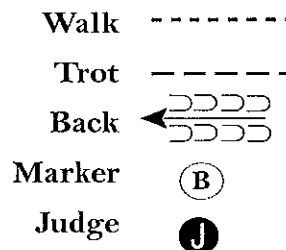

[S/WT-21]

Pattern Provided by:  
*Sandy Jirkovsky*

# Houston Livestock Youth Show

## Showmanship (All Breed Showmanship 13 and under)

Show Date: 03-14-2019

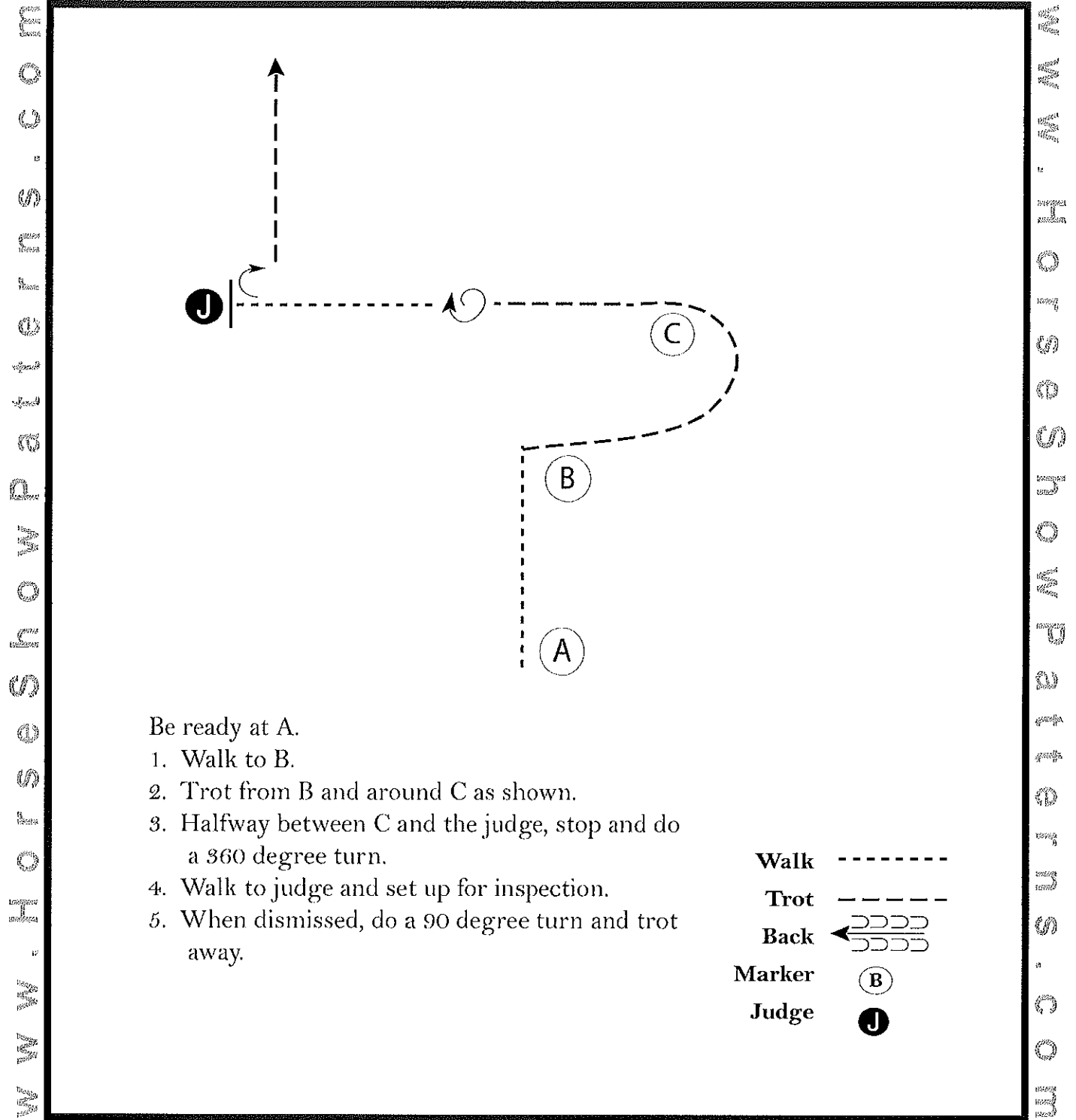

[S/2-21]

Pattern Provided by:  
*Sandy Jirkovsky*

# Houston Livestock Youth Show

Showmanship (All Breed Showmanship 14-18 and Grade 18 and under)

Show Date: 03-14-2019

W W W . H O R S E S H O W P A T T E R N S . C O M

W W W . H O R S E S H O W P A T T E R N S . C O M

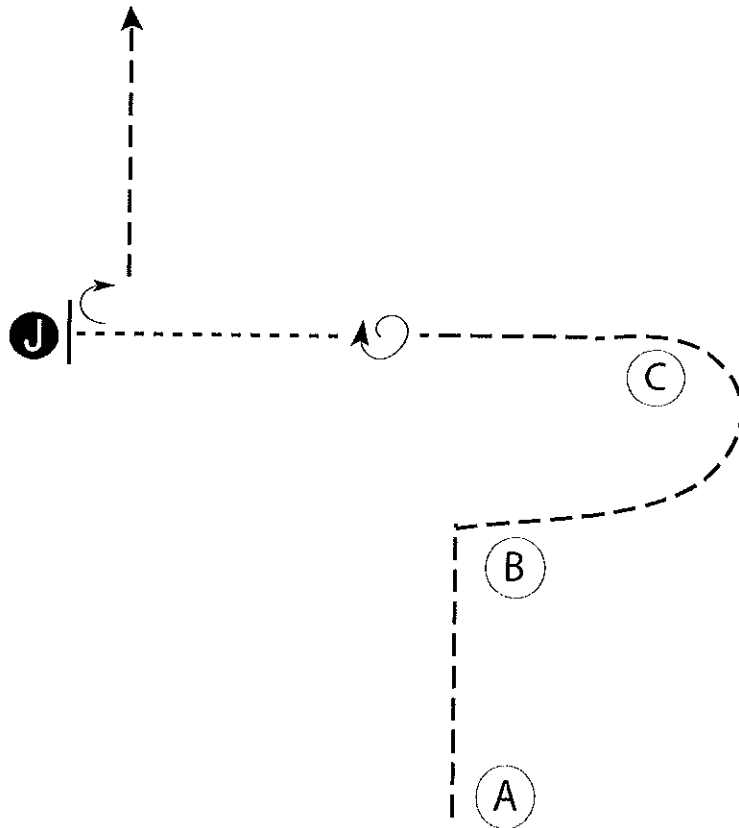

Be ready at A.

1. Trot around B and C as shown.
2. Halfway between C and the judge, stop and do a 360 degree turn.
3. Walk to judge and set up for inspection.
4. When dismissed, do a 90 degree turn and trot away.

Walk	-----
Trot	- - - - -
Back	←
Marker	ⓑ
Judge	ⓙ

[S/3-21]

Pattern Provided by:  
*Sandy Jirkovsky*

# Houston Livestock Youth Show

## Showmanship (AQHA Novice Youth )

Show Date: 03-14-2019

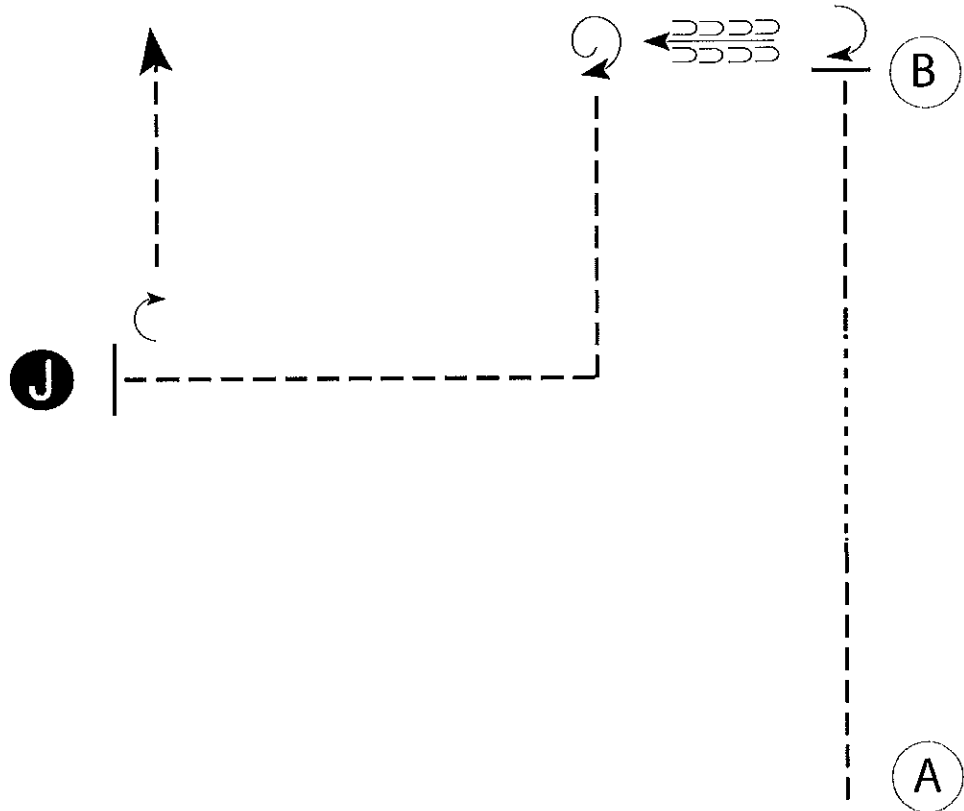

Be ready at A.

1. Trot 1/3 of the line, then walk 1/3 of the line then trot the final 1/3 of the line.
2. Stop with horse's hip even with B then perform a 1/4 turn.
3. Back 2 horse lengths then perform a 1 1/4 turn.
4. Trot to judge as shown.
5. Stop and set up at Judge.
6. Inspection.
7. When dismissed, perform a 1/4 turn and trot to exit.

Walk -----  
 Trot - - - - -  
 Back ← ← ← ← ←  
 Marker (B)  
 Judge (J)

[S/2-119]

Pattern Provided by:  
*Sandy Jirkovsky*

www.horshowpatterns.com

www.horshowpatterns.com

# Houston Livestock Youth Show

## Showmanship (AQHA 13 and under and 14-18)

Show Date: 03-14-2019

W W W . H O R S E S H O W P A T T E R N S . C O M

W W W . H O R S E S H O W P A T T E R N S . C O M

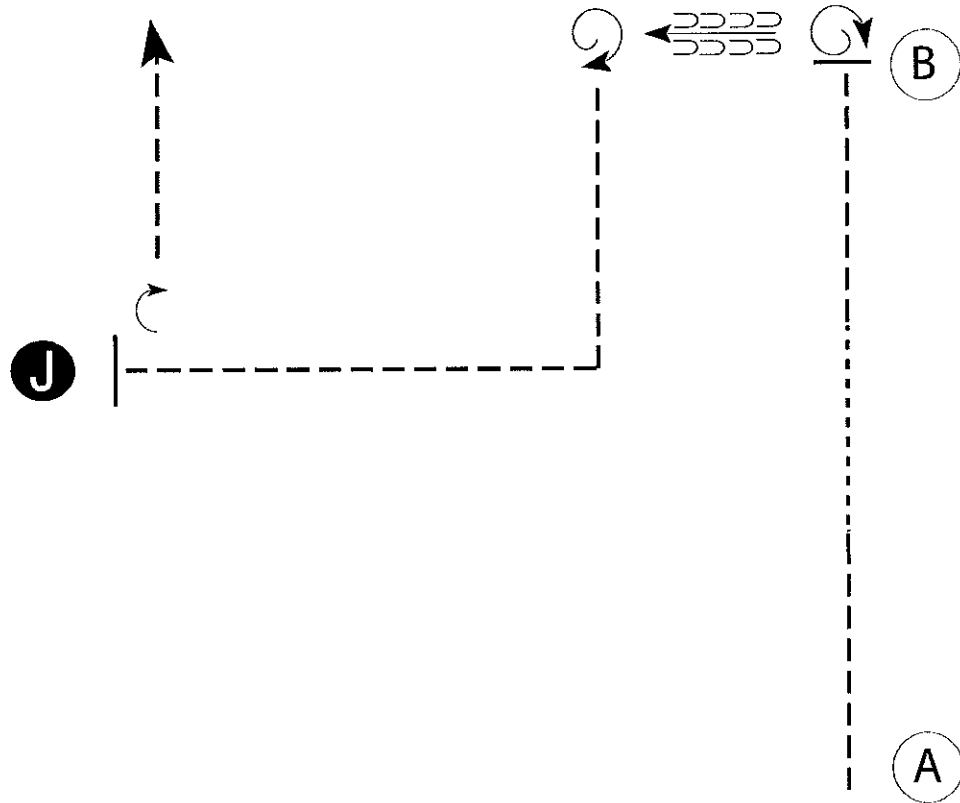

Be ready at A.

1. Trot 1/3 of the line, then walk 1/3 of the line then trot the final 1/3 of the line.
2. Stop with horse's hip even with B then perform a 1 1/4 turn.
3. Back 2 horse lengths then perform a 1 1/4 turn.
4. Trot to judge as shown.
5. Stop and set up at Judge.
6. Inspection.
7. When dismissed, perform a 1/4 turn and trot to exit.

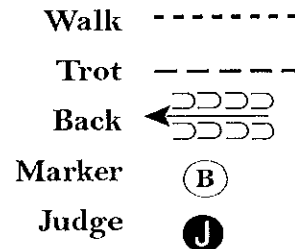

[S/3-119]

Pattern Provided by:  
*Sandy Jirkovsky*

# Houston Livestock Youth Show

## Hunt Seat Equitation (Walk Trot)

Show Date: 03-14-2019

W W W . H O R S E S H O W P A T T E R N S . C O M

W W W . H O R S E S H O W P A T T E R N S . C O M

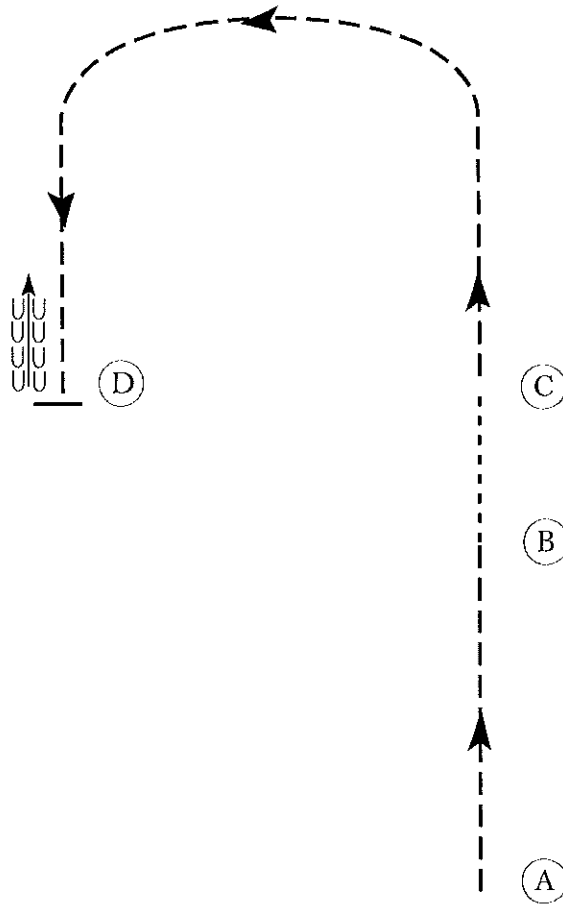

Be ready at A.

1. Posting trot on the left diagonal from A to B.
2. Walk from B to C.
3. Posting trot on the right diagonal from C to D.
4. Stop and back approximately one horse length at D.

Exit at a sitting trot.

Walk	-----
Trot	- - - - -
Extended Trot	- - - - -
Canter	—————
Leg Yield	
Lead Change	— / —
Back	←←←←←
Marker	(B)
Sidepass	← - - - - ←
Hand Gallop	—————

[HSE/WT-20]

Pattern Provided by:  
*Sandy Jirkovsky*

# Houston Livestock Youth Show

## Hunt Seat Equitation (All Breed Hunt Seat Equitation 13 and under)

Show Date: 03-14-2019

www.horshowpatterns.com

www.horshowpatterns.com

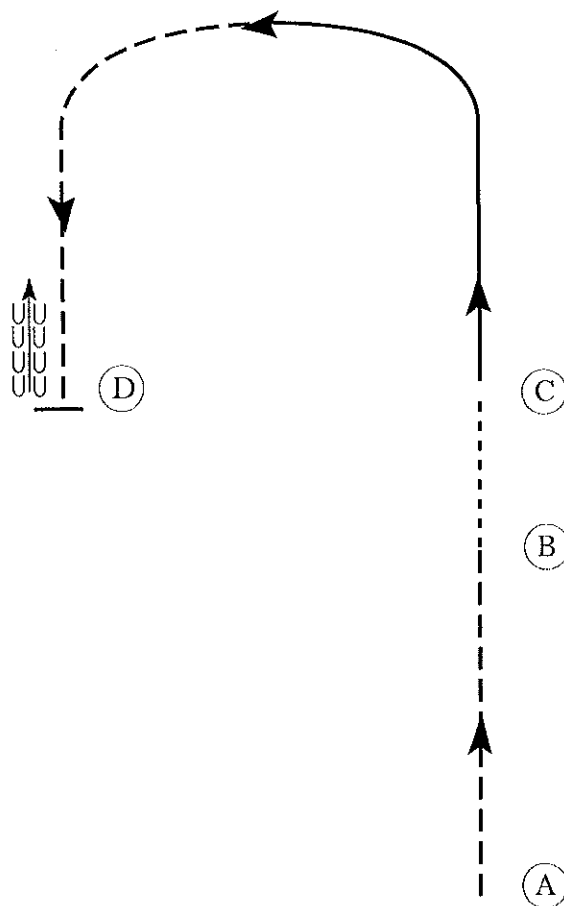

Be ready at A.

1. Posting trot on the left diagonal from A to B.
2. Walk from B to C.
3. Left lead canter at C.
4. When at the top of the arc, transition to a posting trot on the right diagonal to D.
5. Stop and back approximately one horse length at D.

Exit at a sitting trot.

Walk	-----
Trot	- - - - -
Extended Trot	—————
Canter	—————
Leg Yield	
Lead Change	↘
Back	←←←←←
Marker	(B)
Sidepass	←←←←←
Hand Gallop	—————

[HSE/1-20]

Pattern Provided by:  
*Sandy Jirkovsky*



# Houston Livestock Youth Show

## Hunt Seat Equitation (All Breed Hunt Seat Equitation 14-18 and Grade)

Show Date: 03-14-2019

www.horsheshowpatterns.com

www.horsheshowpatterns.com

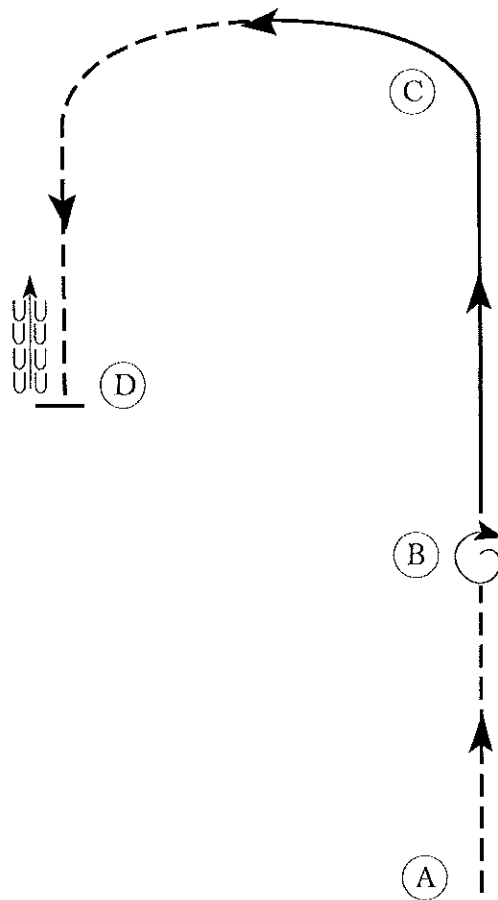

Be ready at A.

1. Posting trot on the left diagonal from A to B.
2. Stop at B and turn on the forehand 360 degrees to the right.
3. At B, canter on the right lead.
4. At the top of the arc, transition to the posting trot to D.
5. Stop and back approximately one horse length at D.

Exit at a sitting trot.

Walk	-----
Trot	- - - - -
Extended Trot	— — — — —
Canter	— — — — —
Leg Yield	
Lead Change	— — — — —
Back	←←←←←
Marker	(B)
Sidepass	← - - - -
Hand Gallop	— — — — —

[HSE/2-22]

Pattern Provided by:  
*Sandy Jirkovsky*

# Houston Livestock Youth Show

## Hunt Seat Equitation (AQHA Novice Youth)

Show Date: 03-14-2019

www.horsheshowpatterns.com

www.horsheshowpatterns.com

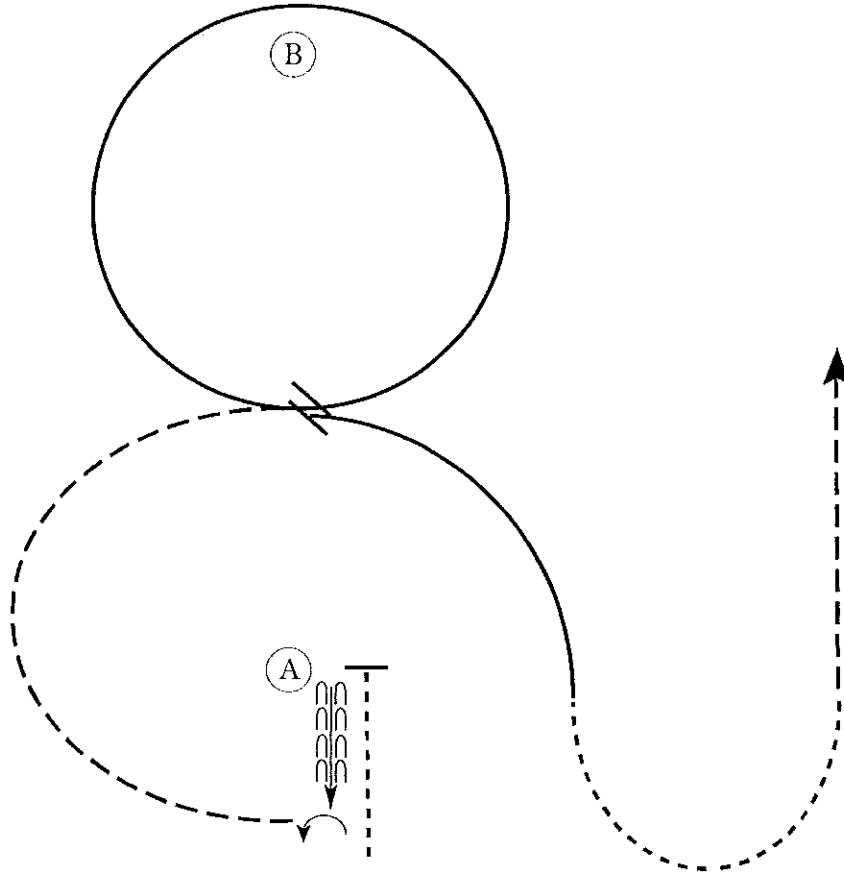

Be ready before A.

1. Walk to A. Back approximately one horse length the perform a 1/4 turn on the forehand left.
2. Posting trot on the left diagonal to center
3. Canter a circle around B on the left lead.
4. Change leads in the center and center on the right lead until even with A.
5. Walk a half circle.
6. Posting trot on the right diagonal to exit.

Follow the instructions of your ring steward.

Walk	-----
Trot	- - - - -
Extended Trot	-----
Canter	=====
Leg Yield	
Lead Change	↘↙
Back	←←←←←
Marker	⊙
Sidepass	←←←←←
Hand Gallop	-----

[HSE/2-72]

**Pattern Provided by:**  
*Sandy Jirkovsky*

# Houston Livestock Youth Show

## Hunt Seat Equitation (AQHA 13 and under and 14-18)

Show Date: 03-14-2019

www.horsheshowpatterns.com

www.horsheshowpatterns.com

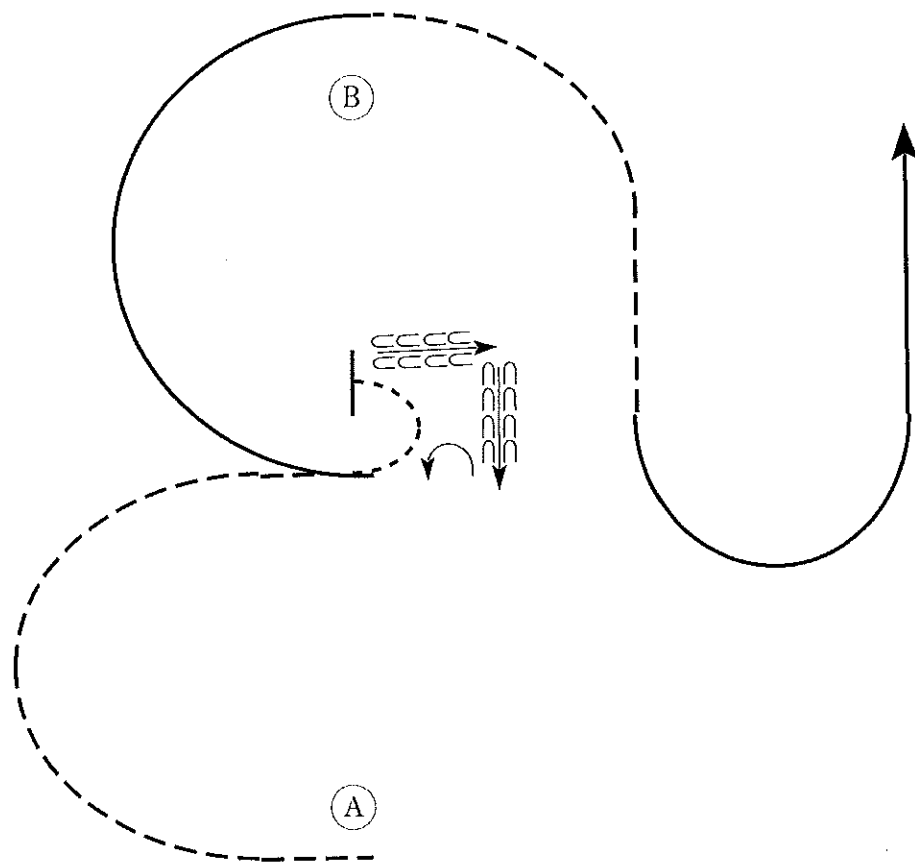

Be ready at A.

1. Posting trot to center of pattern.
2. Break to a walk and walk a small half circle.
3. Stop and back a square corner.
4. Perform a 1/4 turn on the forehand left.
5. Canter on the right lead to B.
6. Posting trot on the left diagonal to center of pattern.
7. Left lead canter in a half circle and to exit.

Follow the instructions of your ring steward.

Walk	-----
Trot	- - - - -
Extended Trot	—————
Canter	—————
Leg Yield	
Lead Change	—/—
Back	←←←←←
Marker	⊙
Sidepass	←←←←←
Hand Gallop	—————

[HSE/3-73]

**Pattern Provided by:**  
*Sandy Jirkovsky*

# Houston Livestock Youth Show

## Trail (Walk Trot)

Show Date: 03-14-2019

www.HorseShowPatterns.com

www.HorseShowPatterns.com

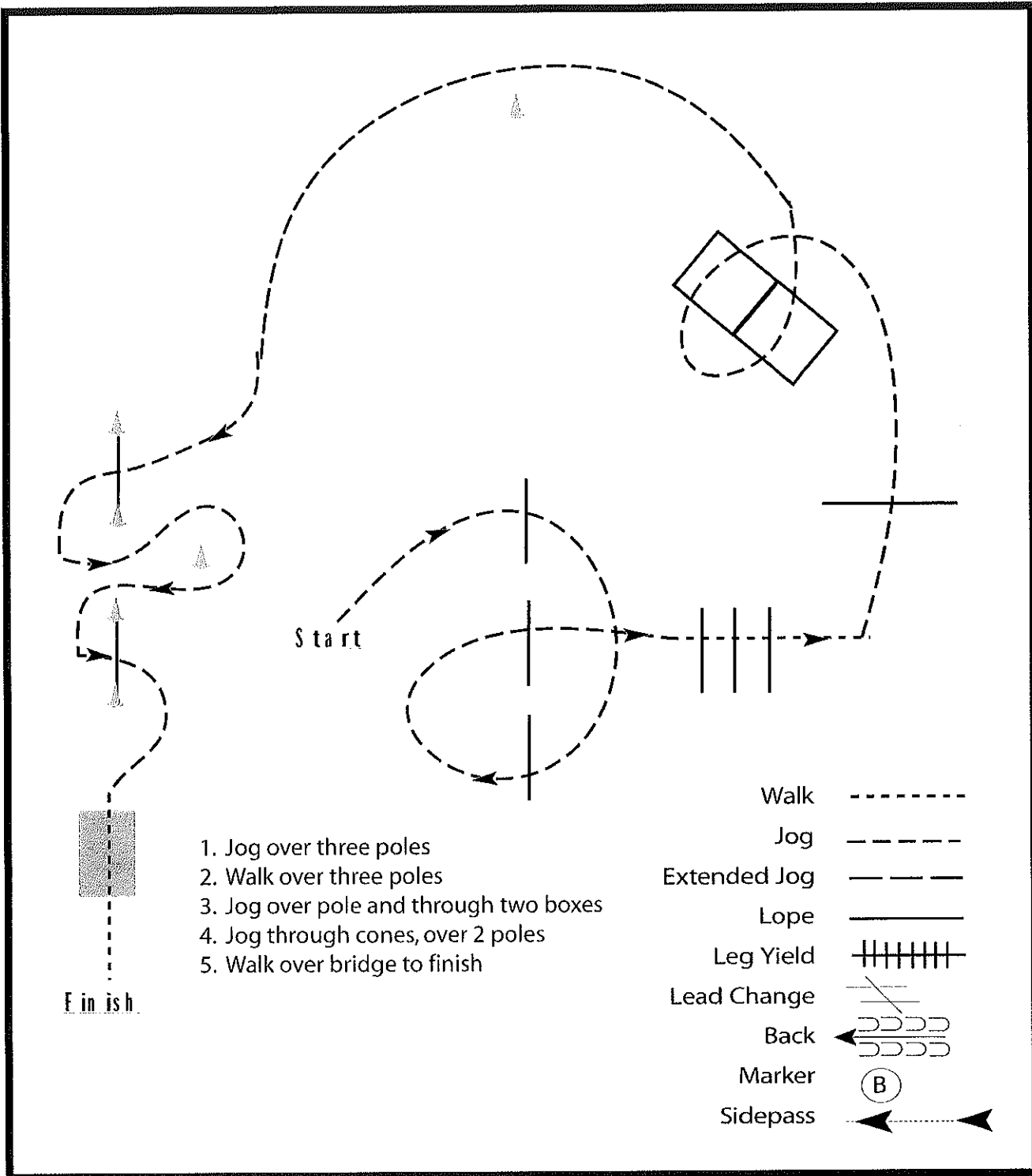

1. Jog over three poles
2. Walk over three poles
3. Jog over pole and through two boxes
4. Jog through cones, over 2 poles
5. Walk over bridge to finish

Walk	-----
Jog	- - - - -
Extended Jog	- . - . - .
Lope	—————
Leg Yield	
Lead Change	— / —
Back	← ~ ~ ~
Marker	(B)
Sidepass	← - - - - →

[T/WT-13]

Pattern Provided by:  
**Sandy Jirkovsky**

# Houston Livestock Youth Show

## Trail (All Breed and Grade)

Show Date: 03-14-2019

www.HorseShowPatterns.com

www.HorseShowPatterns.com

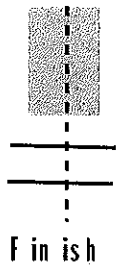
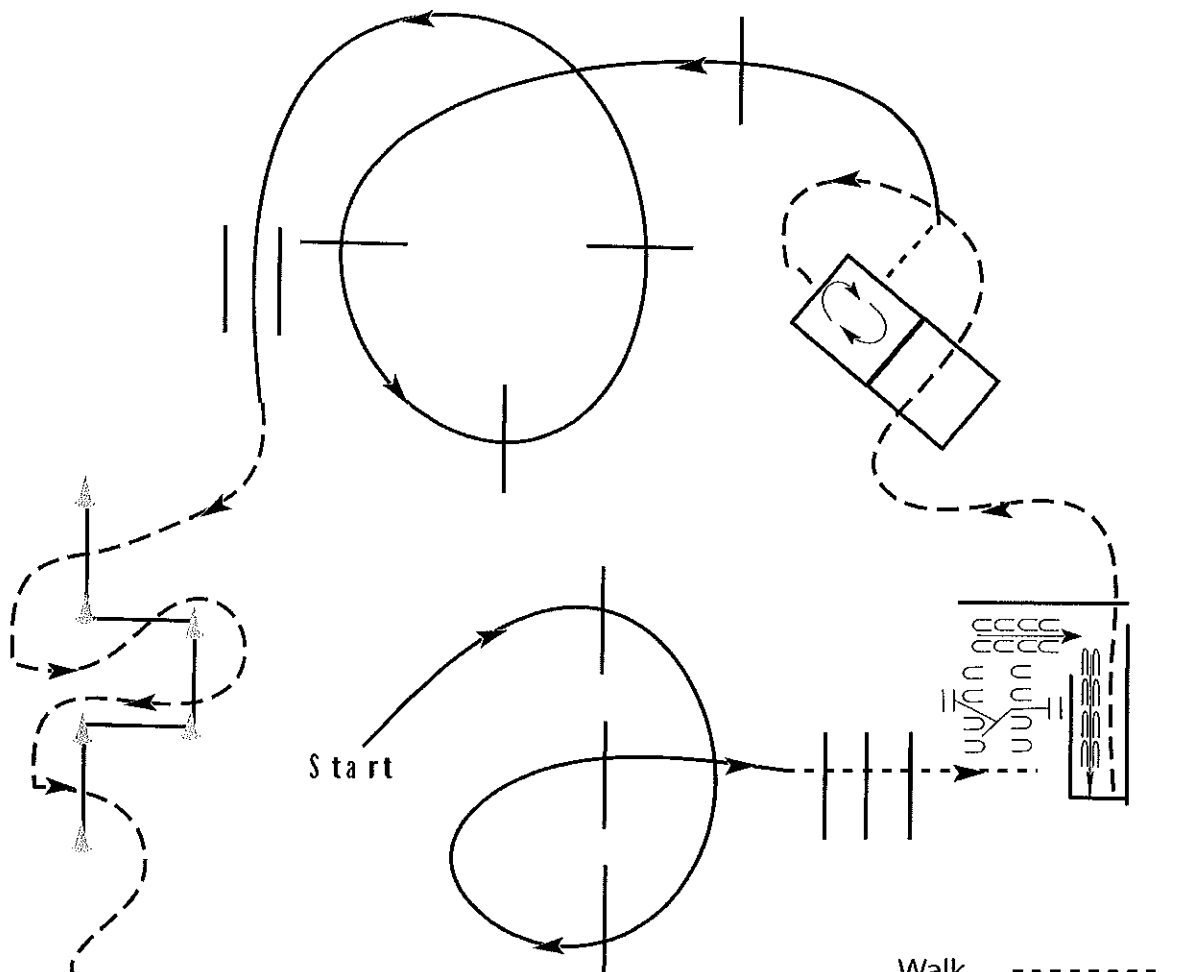

Finish

1. Lope on the right lead over poles
2. Walk over poles to gate
3. Left hand push gate and back L
4. Jog out of chute and over poles into box
5. 3/4 turn to the right in box and walk out of box
6. Lope on the left lead over poles
7. Jog over poles
8. Walk over bridge and over poles to finish

Walk	-----
Jog	- - - - -
Extended Jog	-----
Lope	=====
Leg Yield	
Lead Change	↘
Back	←←←←←
Marker	⊙ (B)
Sidepass	←←←←←

[T/2-13]

Pattern Provided by:

*Sandy Jirkovsky*

# Houston Livestock Youth Show

## Trail (AQHA Novice Youth)

Show Date: 03-14-2019

www.HorseShowPatterns.com

www.HorseShowPatterns.com

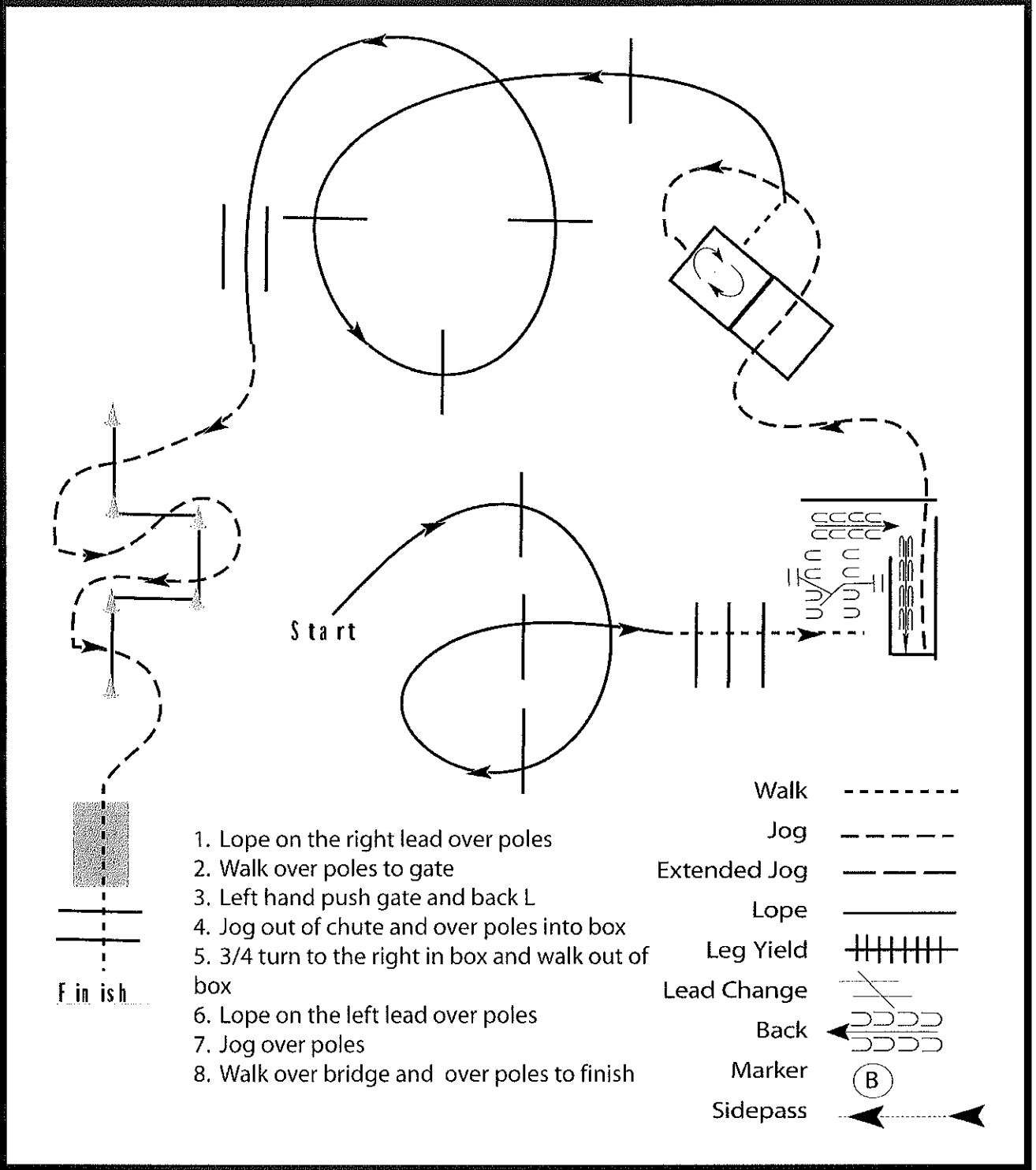

1. Lope on the right lead over poles
2. Walk over poles to gate
3. Left hand push gate and back L
4. Jog out of chute and over poles into box
5. 3/4 turn to the right in box and walk out of box
6. Lope on the left lead over poles
7. Jog over poles
8. Walk over bridge and over poles to finish

Walk	-----
Jog	- - - - -
Extended Jog	- - - - -
Lope	—————
Leg Yield	
Lead Change	///
Back	←←←
Marker	Ⓚ
Sidepass	←-----→

[T/2-13]

Pattern Provided by:  
*Sandy Jirkovsky*

# Houston Livestock Youth Show

## Trail (AQHA 13 and under and 14-18)

Show Date: 03-14-2019

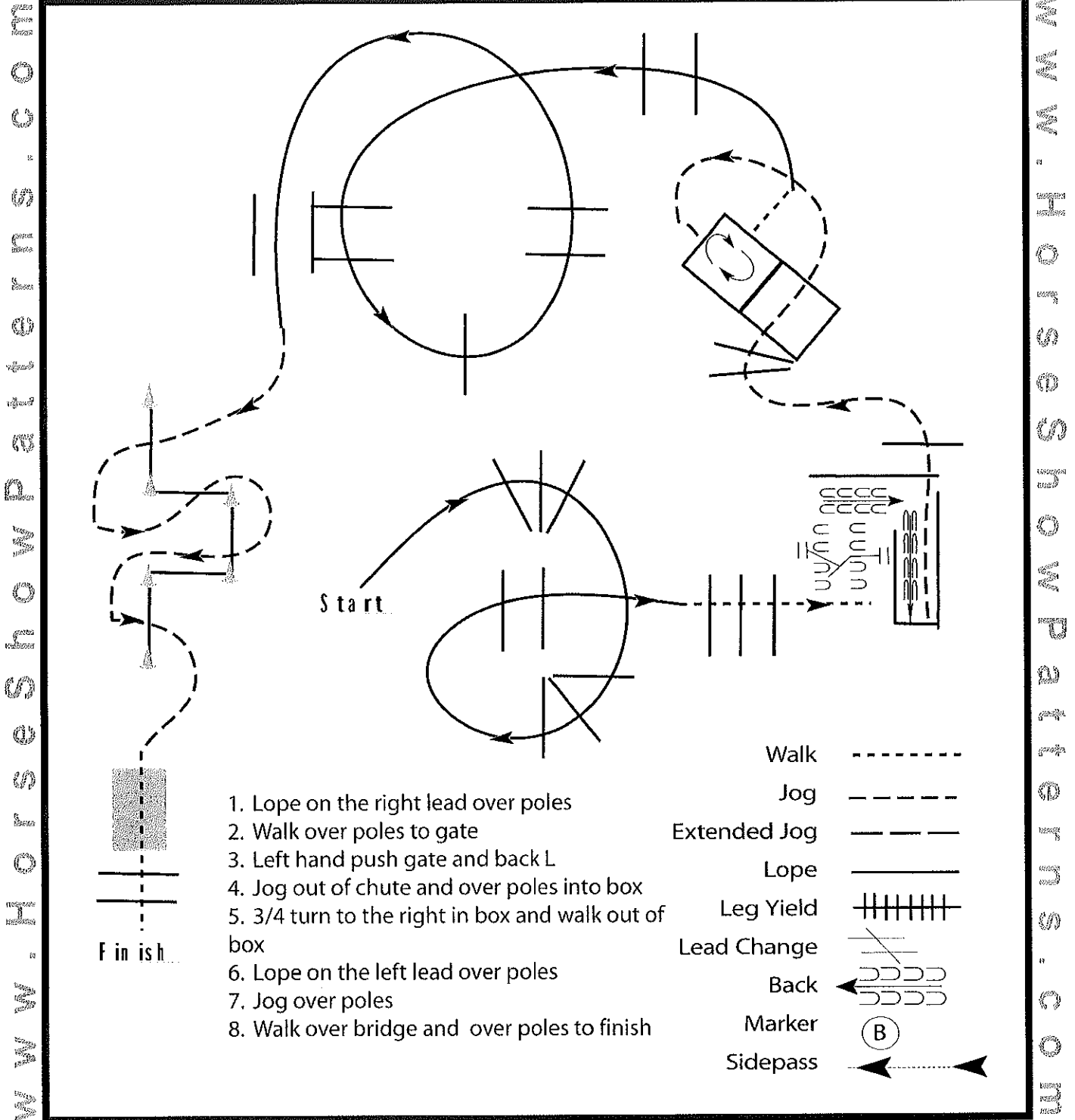

[T/3-10]

Pattern Provided by:

*Sandy Jirkovsky*

# Houston Livestock Youth Show

## Horsemanship (Walk Trot)

Show Date: 03-14-2019

W W W . H O R S E S H O W P A T T E R N S . C O M

W W W . H O R S E S H O W P A T T E R N S . C O M

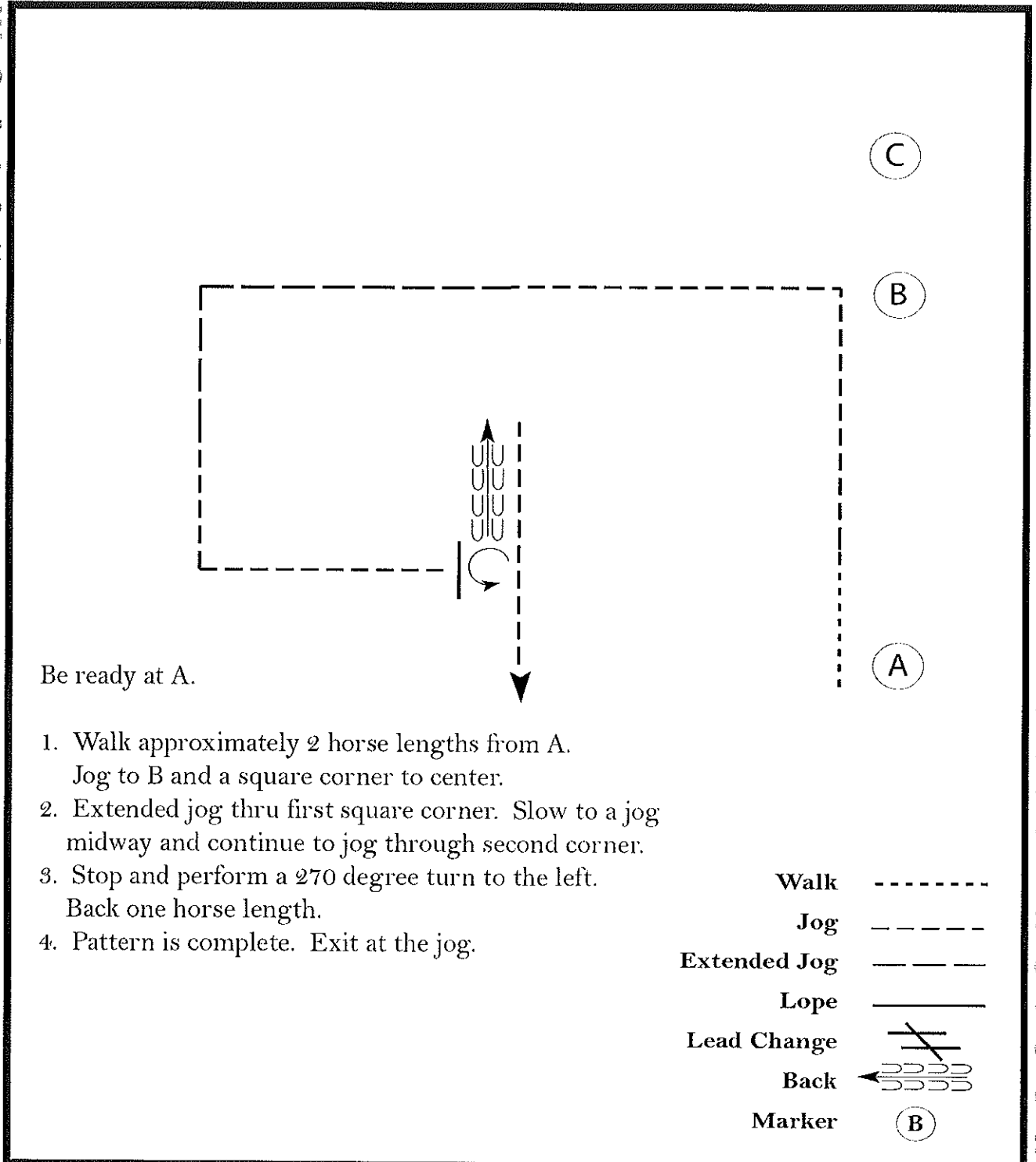

[WH/WT-108]

Pattern Provided by:  
*Sandy Jirkovsky*



# Houston Livestock Youth Show

## Horsemanship (All Breed and Grade)

Show Date: 03-14-2019

www.horshowpatterns.com

www.horshowpatterns.com

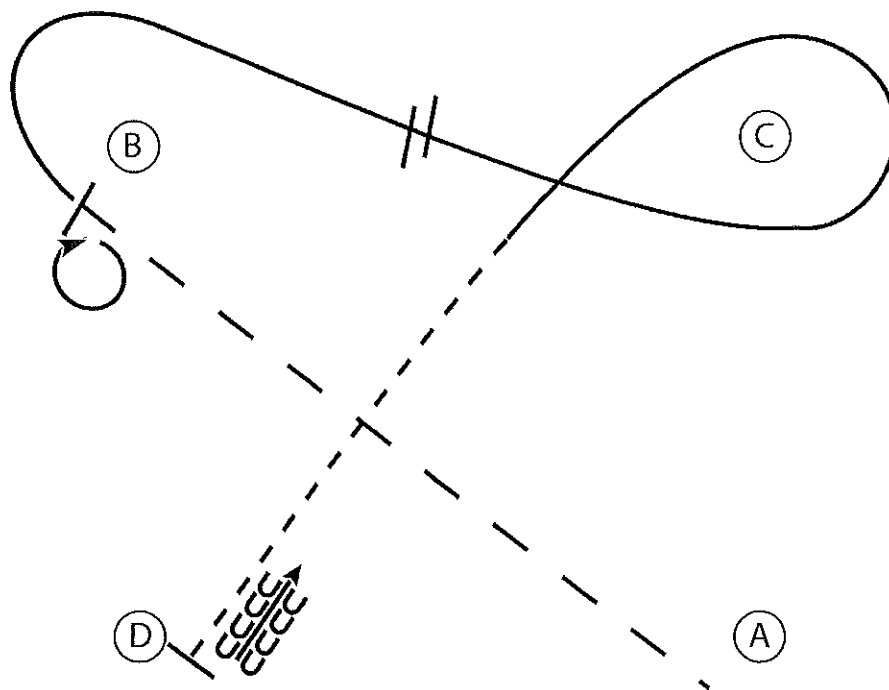

1. Extend the jog A to B
2. Stop at B and perform a 360 degree turn to the right
3. Lope on the right lead around B
4. Half way between B and C change leads and continue to and around C
5. Jog halfway between C and D
6. At D stop and back

Walk	.....
Jog	-----
Extended Jog	-----
Lope	—————
Leg Yield	
Lead Change	—/—
Back	←←←←←
Marker	(B)
Sidepass	←→

[WH/2-27]

**Pattern Provided by:**  
*Sandy Jirkovsky*

# Houston Livestock Youth Show

## Horsemanship (AQHA Novice Youth)

Show Date: 03-14-2019

www.horshowpatterns.com

www.horshowpatterns.com

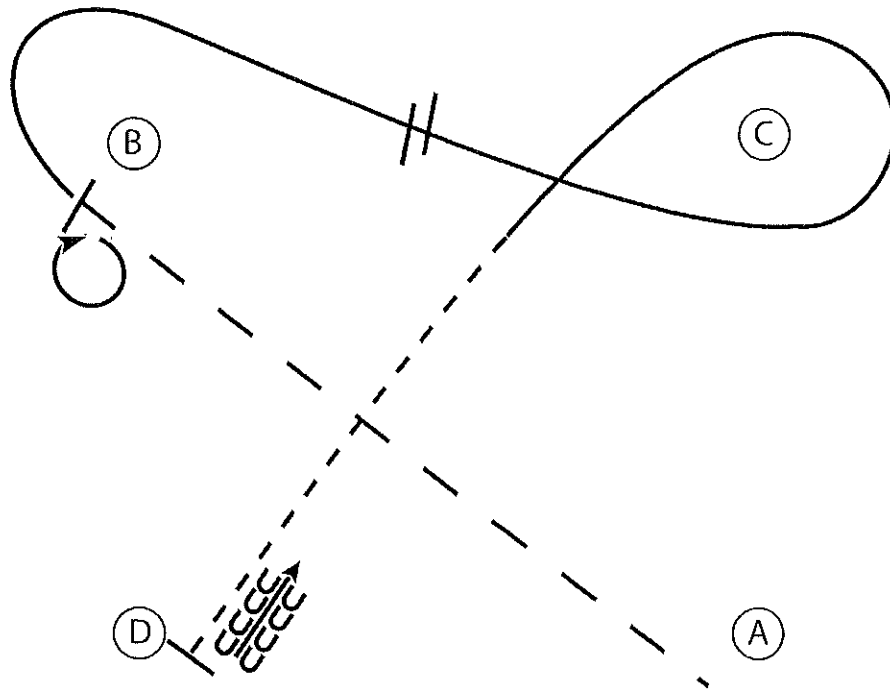

1. Extend the jog A to B
2. Stop at B and perform a 360 degree turn to the right
3. Lope on the right lead around B
4. Half way between B and C change leads and continue to and around C
5. Jog halfway between C and D
6. At D stop and back

Walk	.....
Jog	-----
Extended Jog	-----
Lope	—————
Leg Yield	
Lead Change	↙↘
Back	←←←←
Marker	⊙
Sidepass	←→

[WH/2-27]

**Pattern Provided by:**  
*Sandy Jirkovsky*

# Houston Livestock Youth Show

## Horsemanship (AQHA 13 and under and 14-18)

Show Date: 03-14-2019

www.horshowpatterns.com

www.horshowpatterns.com

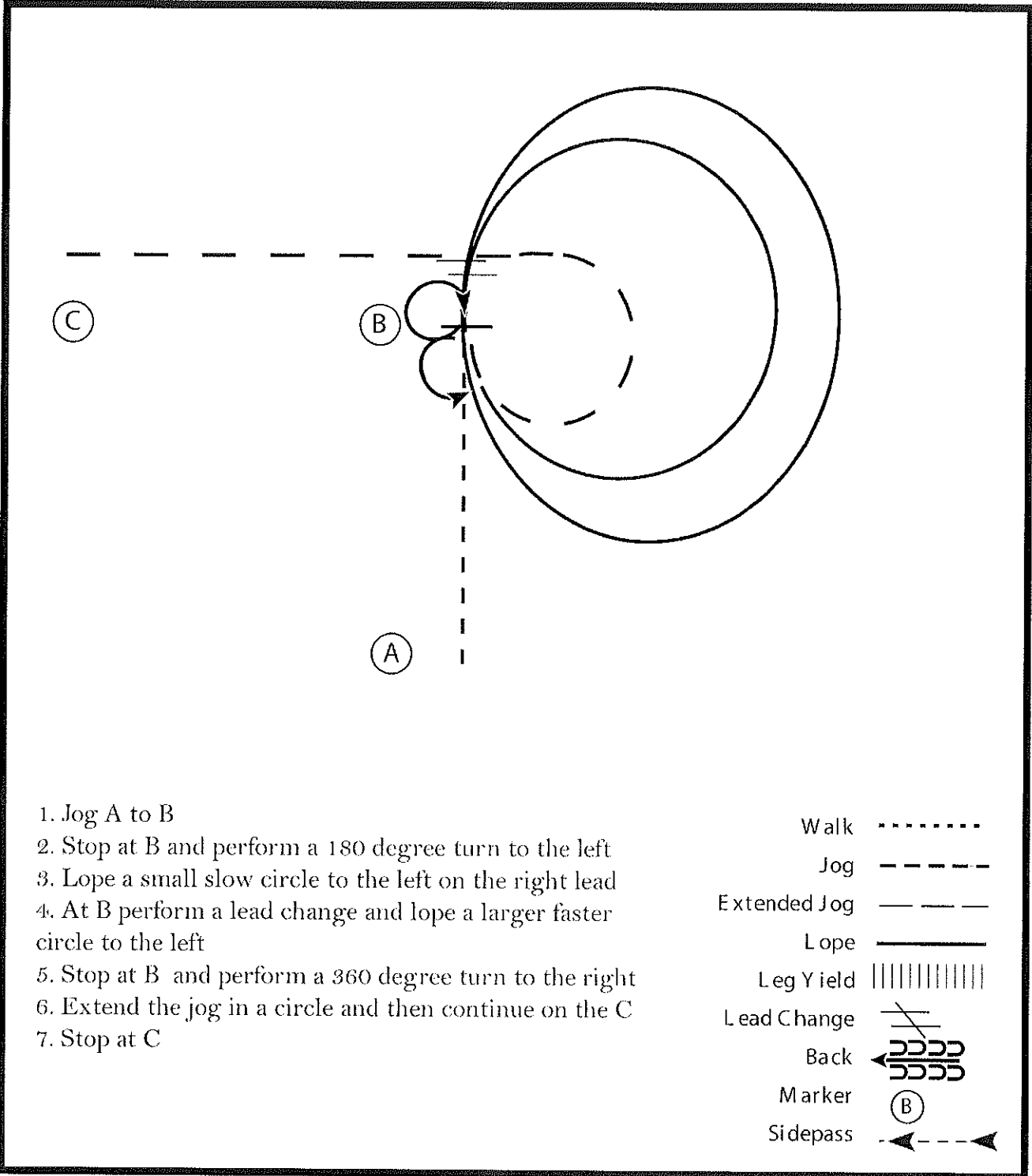

1. Jog A to B
2. Stop at B and perform a 180 degree turn to the left
3. Lope a small slow circle to the left on the right lead
4. At B perform a lead change and lope a larger faster circle to the left
5. Stop at B and perform a 360 degree turn to the right
6. Extend the jog in a circle and then continue on the C
7. Stop at C

- Walk ..... (dotted line)
- Jog - - - - - (dashed line)
- Extended Jog - - - - - (long dashed line)
- Lope \_\_\_\_\_ (solid line)
- Leg Yield ||||| (vertical lines)
- Lead Change (diagonal line with slash)
- Back (curved lines pointing left)
- Marker (B) (circle with B)
- Sidepass (dashed line with arrow)

[WH/3-12]

**Pattern Provided by:**  
*Sandy Jirkovsky*

# Houston Livestock Youth Show

## All Breed Ranch Riding (ALL)

Show Date: 03-14-2019

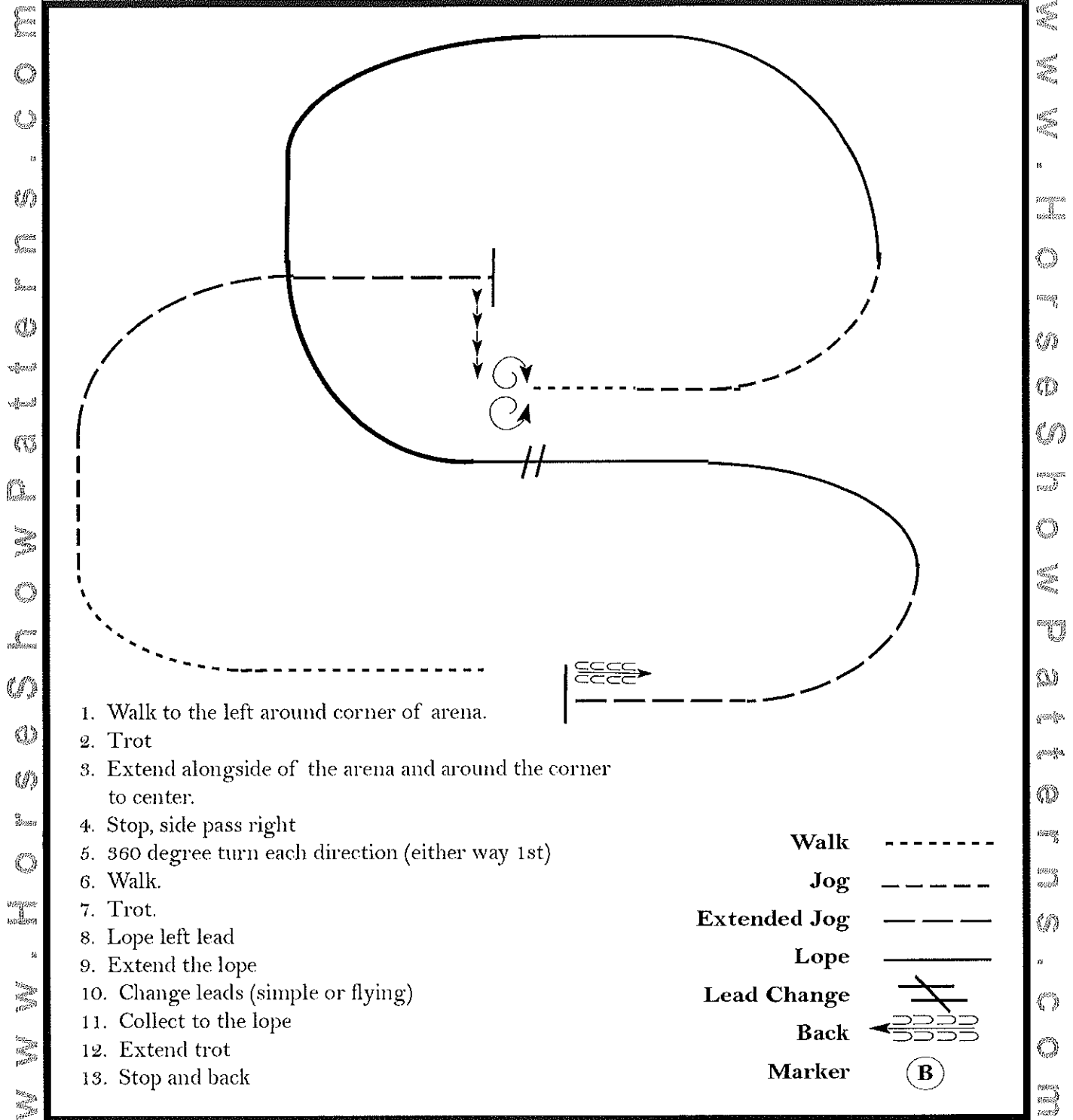

[RR/3]

Pattern Provided by:

*Sandy Jirkovsky*

# Houston Livestock Youth Show

All Breed Ranch Reining,  
Reining (All Breed and Grade Reining)

Show Date: 03-14-2019

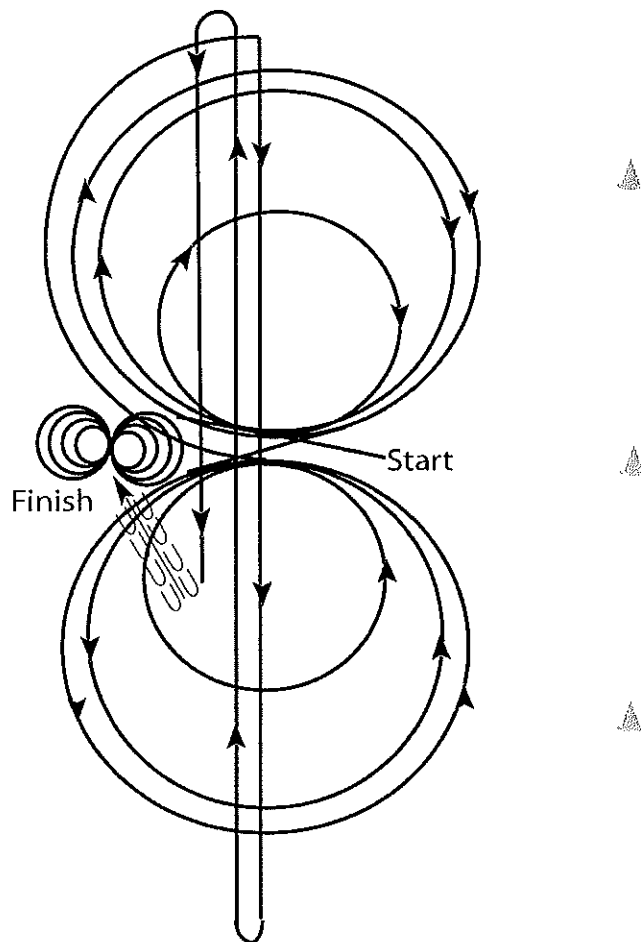

Horses must walk or stop prior to starting the pattern.

Begin at the center of the arena facing the left wall or fence.

1. Beginning on the right lead, complete three circles to the right; the first small and slow; the next two circles large and fast. Change leads at the center of the arena.
  2. Complete three circles to the left; the first small and slow; the next two circles large and fast. Change leads at the center of the arena.
  3. Continue around previous circle to the right. At the top of the circle, run down the middle to the far end of the arena past the end marker and do a right rollback - no hesitation.
  4. Run up the middle to the opposite end of the arena past the end marker and do a left rollback - no hesitation.
  5. Run past the center marker and do a sliding stop. Back up to the center of the arena or at least 10 feet (3m). Hesitate.
  6. Complete four spins to the right.
  7. Complete four spins to the left. Hesitate to demonstrate completion of the pattern.
- Rider may drop bridle to the designated judge.

[R/AQHAP-2]

Pattern Provided by:  
*Sandy Jirkovsky*

# Houston Livestock Youth Show

## Reining (AQHA Reining)

Show Date: 03-14-2019

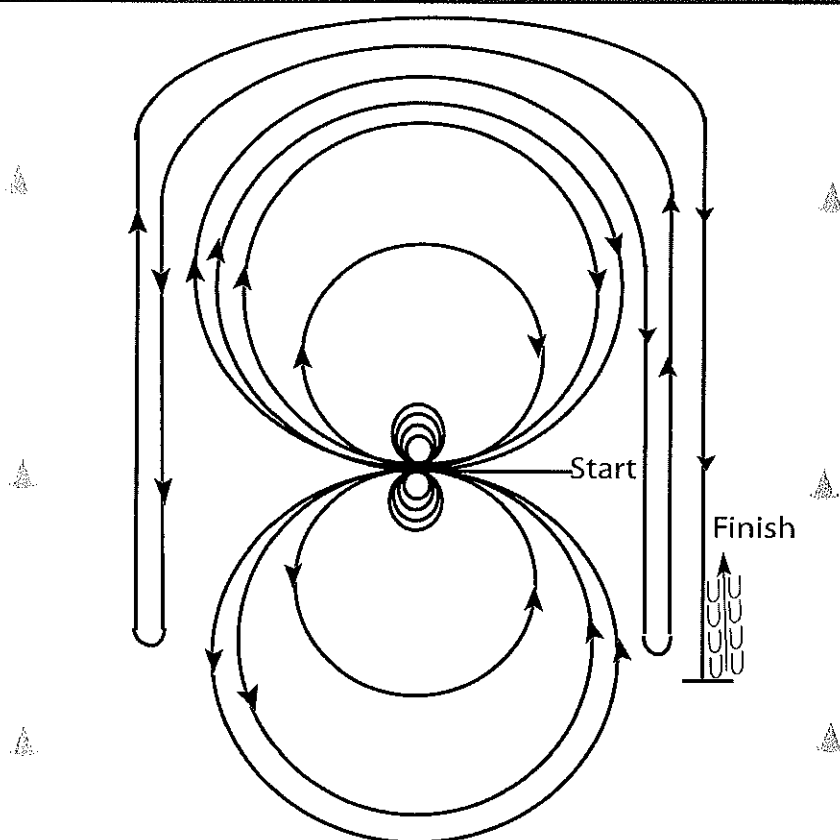

Horses must walk or stop prior to starting pattern. Beginning at the center of the arena facing the left wall or fence.

1. Complete four spins to the left.
  2. Complete four spins to the right. Hesitate.
  3. Beginning on the right lead, complete three circles to the right: the first circle large and fast; the second circle small and slow; the third circle large and fast. Change leads at the center of the arena.
  4. Complete three circles to the left: the first circle large and fast; the second circle small and slow; the third circle large and fast. Change leads at the center of the arena.
  5. Begin a large fast circle to the right but do not close this circle. Run straight down the right side of the arena past the center marker and do a left rollback at least twenty feet (6.09m) from the wall or fence – no hesitation.
  6. Continue back around the previous circle but do not close this circle. Run down the left side of the arena past the center marker and do a right rollback at least twenty feet (6.09m) from the wall or fence – no hesitation.
  7. Continue back around the previous circle but do not close this circle. Run down the right side of the arena past the center marker and do a sliding stop at least twenty feet (6.09m) from the wall or fence. Back up at least ten feet (3m). Hesitate to demonstrate completion of the pattern.
- Rider may drop bridle to the designated judge.

[R/AQHAP-8]

**Pattern Provided by:**  
*Sandy Jirkovsky*